



DISPOSABLE PRESSURE TRANSDUCER

Why FMT Disposable Pressure Transducer?



- Consistent and accurate readings during blood pressure monitoring.
- High durometer pressure tubing ensures optimal dynamic response.
- The convenient snap-tap flush device designed for easy priming and square-wave testing.
- Multiple Standard Configurations, Adult and neonatal/pediatric.
- Components that simplify setup.
- The transducer can easily be mounted on either the patient bed or IV pole.
- Fully integrated flow-through component design simplifies filling and debubbling.
- Versatile, dual function snap tab allows dynamic response testing.
- Superior fluid path visualization.
- 3cc or 30cc per hour flow rates with dual function flush device.
- Administration sets are pre-connected to the IBP Transducer sets are sterile and individually packaged.

Technical Specifications

	Parameter	Value			Units	Notes
		Min.	Nom.	Max.		
Electrical	Operating Pressure Range	-50		300	mmHg	
	Overpressure (Tolerance/Protection)	-400		4000	mmHg	
	Zero Pressure Output / Offsets	-20		20	mmHg	
	Input Impedance	1200		3200	Ω	
	Output Impedance	285		315	Ω	
	Supply (Excitation) Voltage & Frequency	2	6	10	VDC; or VAC RMS to 5kHz	
	Leakage(Risk) Current			2	μ A	@230 V RMS, 50 Hz
Warm Up Time		5		Sec.		
	Dielectric Breakdown		10.000		VDC	
Performance	Sensitivity	4.9	5.0	5.1	μ V / V / mmHg	
	Nonlinearity and Hysteresis	-1.5		1.5	%Span	0 to 300 mmHg
	Zero Thermal Drift (Thermal Offset Shift)	-0.3		0.3	mmHg / °C	
	Sensitivity Thermal Drift (Thermal Span Shift)	-0.1		0.1	% / °C	@10-40°C with respect to 23°C
	Frequency Response		1200		Hz	
	Zero (Offset) Drift With Time			2	mmHg / 8 hrs	after a 10 minute warm-up.
	Phase Shift				5°	@5 kHz
	Unbalance	-75		75	mmHg	
	Defibrillator withstand (360 joules)	5			Discharges / min	
	Natural Frequency		40		Hz	in saline
	Continuous Flow Rate		3±1 or 30±10		cc/hr	@300 mmHg
Environmental	Operating Temperature	15		40	°C	
	Storage Temperature	-25		70	°C	
	Humidity (External)	10		90	%	non-condensing
	Atmosphere Pressure Range	700		1060	hPa	
	Light Sensitivity (@3000 Foot Candle)		1			(per AMMI BP22)
	Mechanical Shock	500			g	2 ms sine, 3 axis
	Operating Life			168	h	
	Shelf Life			3	Years	

Supply Voltage: 6.0 VDC, Ambient Temperature: 25°C (unless otherwise specified). All specifications meet or exceed the AAMI Standard for performance interchangeability of resistance bridge type blood pressure transducers.

Disposable Pressure Transducer

Product Description

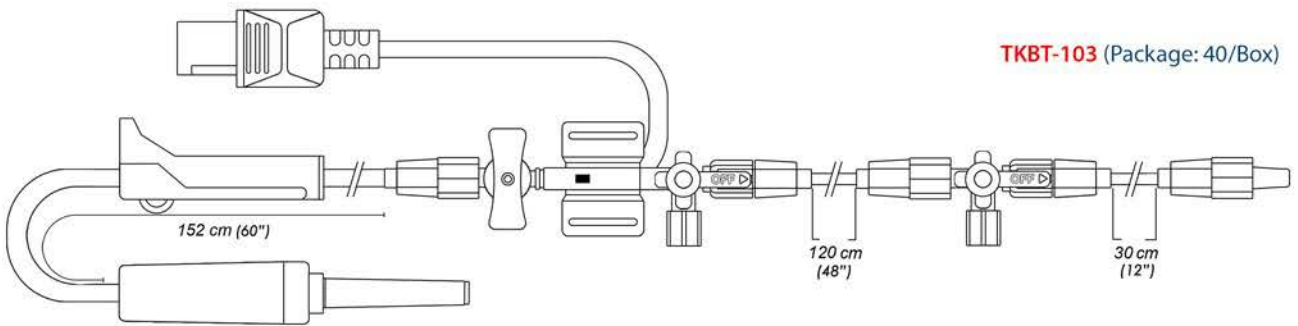

Single Channel Disposable Pressure Transducer Set, (1 piece Disposable Pressure Transducer, 1 piece 152 cm (60") Single IV set, 1 piece Flush Device 3 cc/h, 1 piece 120 cm (48") Pressure Tubing with M/F Connector, 1 piece 30 cm (12") Pressure Tubing with M/F Connector, 2 pieces 3-Way Stopcock, 2 pieces Male Non-Vented Cap).

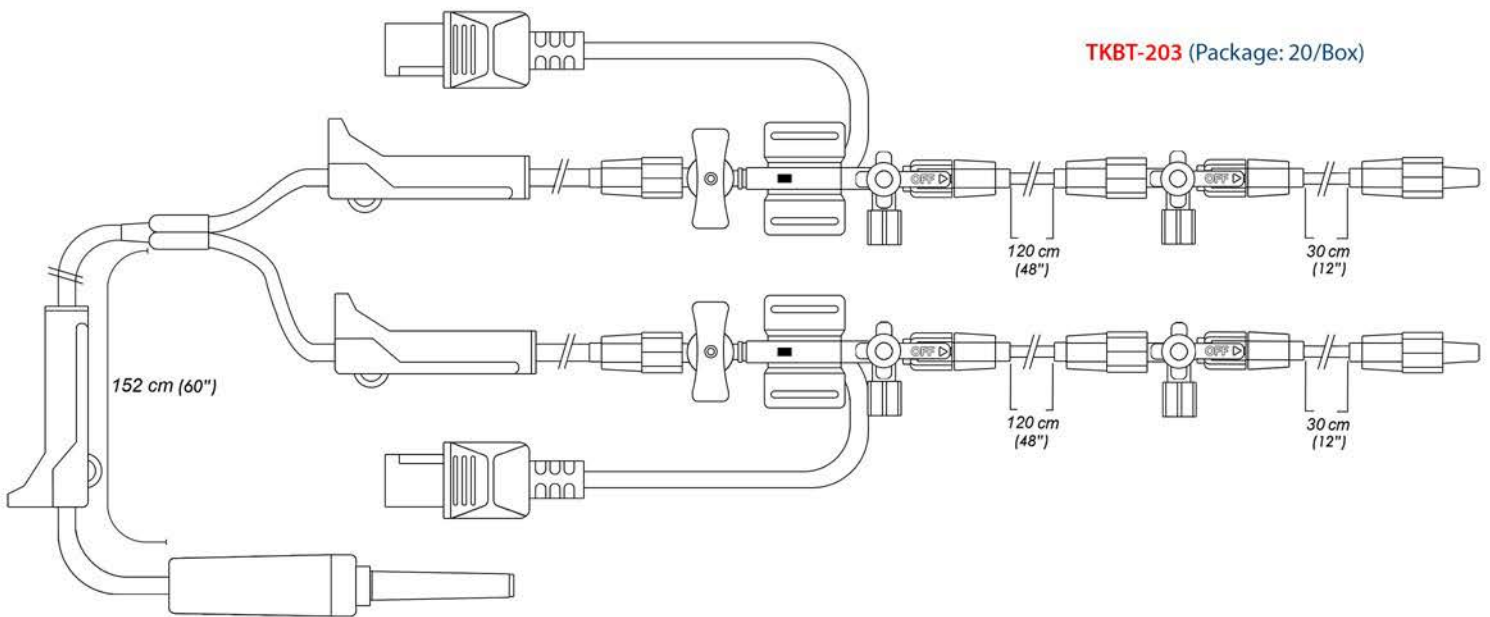

Double Channel Disposable Pressure Transducer Set, (2 pieces Disposable Pressure Transducer, 1 piece 152 cm (60") Single IV set, 2 pieces Flush Device 3 cc/h, 2 pieces 120 cm (48") Pressure Tubing with M/F Connector, 2 pieces 30 cm (12") Pressure Tubing with M/F Connector, 4 pieces 3-Way Stopcock, 4 pieces Male Non-Vented Cap).



TKBT-BP3

Transducer Background Plate for Disposable Pressure Transducer
5/Box

FMT three slot Transducer Background Plate with color coded labels provide easy identification of various components and can be easily adapted to mount to the bedside or an IV pole. Reusable and may be EtO gas-sterilized a limited number of times.



TKBT-CL1 IV Pole Clamp for TKBT-BP3 Transducer Background Plate

1/Each



Accommodates TKBT-BP3 Transducer Background Plate. Uses thumbscrews to secure Transducer Background Plate. Reusable and may be EtO gas-sterilized a limited number of times.

TKBT-AS Patient Attachment Arm Straps (Disposable)

25/Box

Allows conversion of pole-mount kits to patient-mount applications.

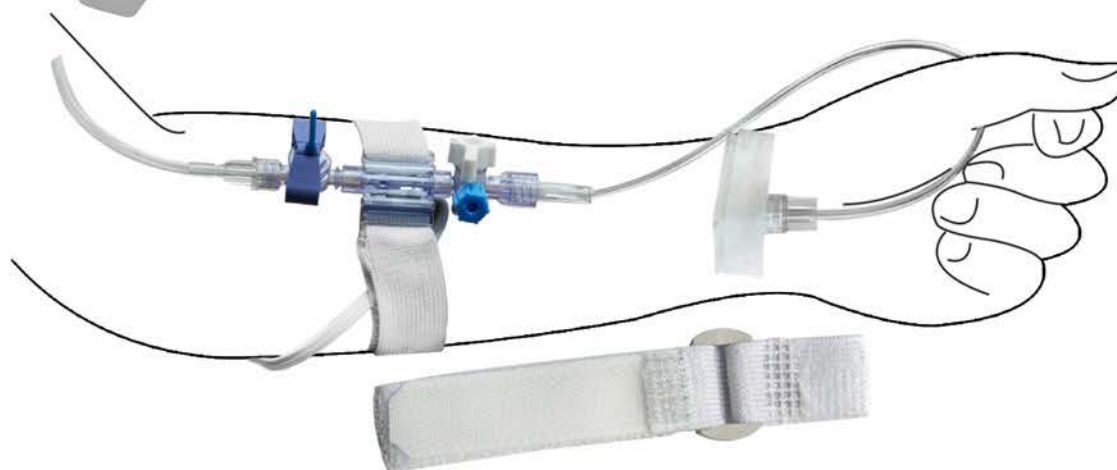

IBP-04/XXX

IBP Interface Cables

1/Each

FMT IBP Cables are for connection between disposable or reusable transducers and the specified monitoring system. All cables are 3.5 m (11') in length and packaged individually. Cables are reusable, non-sterile and can be EtO gas sterilized a limited number of times. Please see FMT IBP Cables product catalogue for compatible monitors.



FMT is registered trademark of **Metko Ltd.**

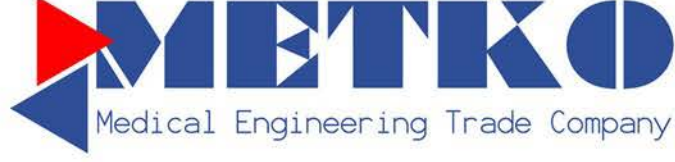

Headquarter & Factory

İvedik O.S.B. Ağaç İşleri Sanayi Sit.
1354. Cad. 1358.Sok. No:9
06378 Yenimahalle

ANKARA / TÜRKİYE

Tel (pbx) : +90 312 387 12 46
Fax : +90 312 387 12 51

Branch

Atatürk Mah. Sedef Cad. 38.Ada
Ata Plaza 3-5 Blokları Kat:2 No:57
34758 Ataşehir

İSTANBUL / TÜRKİYE

Tel (pbx) : +90 216 455 91 21
Fax : +90 216 455 48 24

www.metkold.com

Other products, logos and company names mentioned herein may be trademarks of their respective owners and are not to be taken as an endorsement of affiliation with FMT®. The information in this catalogue has been carefully checked and it is believed to be accurate. Images in this catalogue are representative of items offered. Actual product may have slight visual differences. In the interest of continued product development, Metko reserves the right to make changes and improvements to this catalogue and the product it described any time, without notice or obligation.